

# The Greenland Telescope

Ming-Tang Chen

Academia Sinica, Institute of Astronomy & Astrophysics

on behalf of  
The GLT Project



Academia Sinica Institute for  
Astronomy & Astrophysics

CENTER FOR **ASTROPHYSICS**  
HARVARD & SMITHSONIAN

Aarhus University, Niels Bohr Institute,  
Technical University of Denmark,  
the University of Southern Denmark

# 超大黑洞的（電波）影像

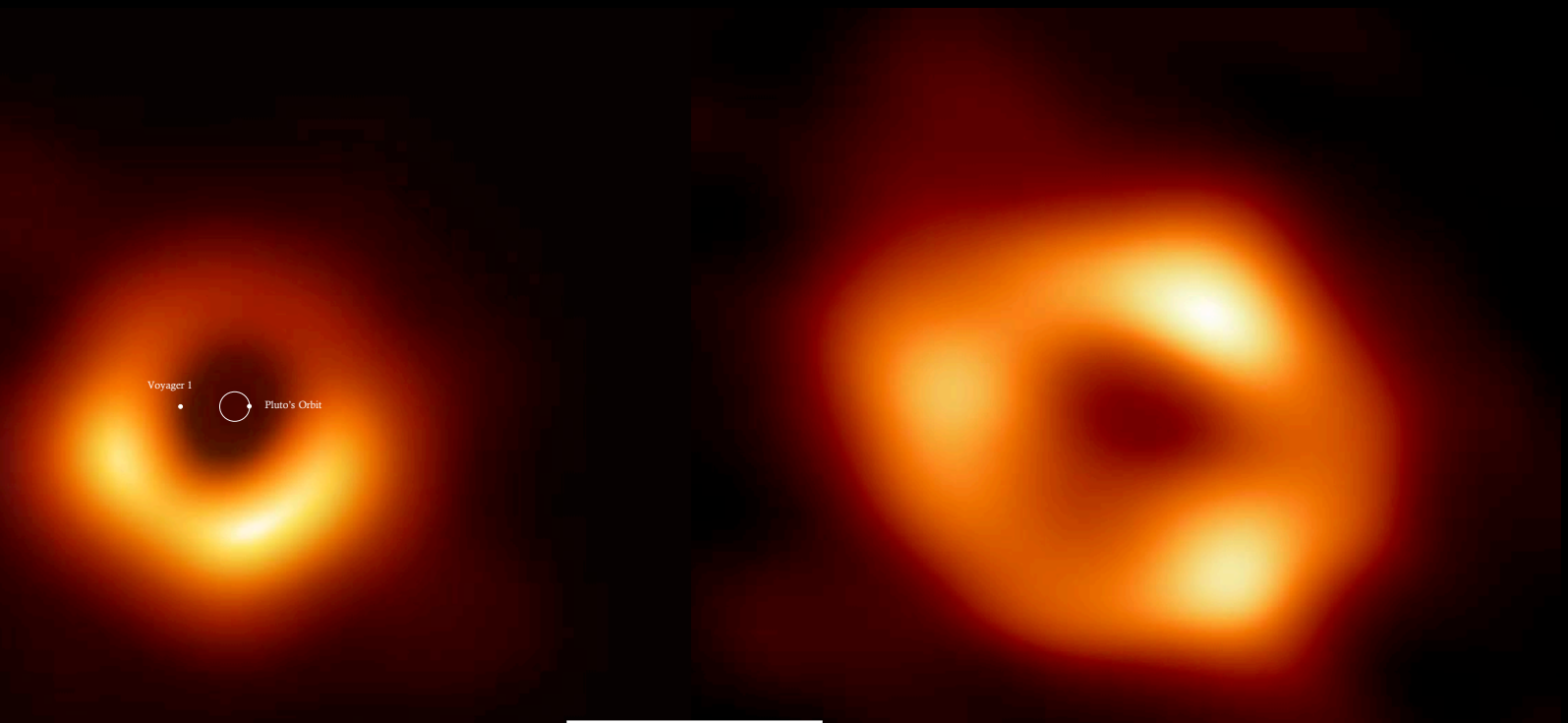

M87 星系中心  
距離 5500 萬光年  
65 億太陽質量

50  $\mu\text{as} \approx 10 \theta_g$   
5 times of Schwarzschild Radius

銀心黑洞（Sgr A\*）  
距離 26 000 光年  
4 百萬太陽質量

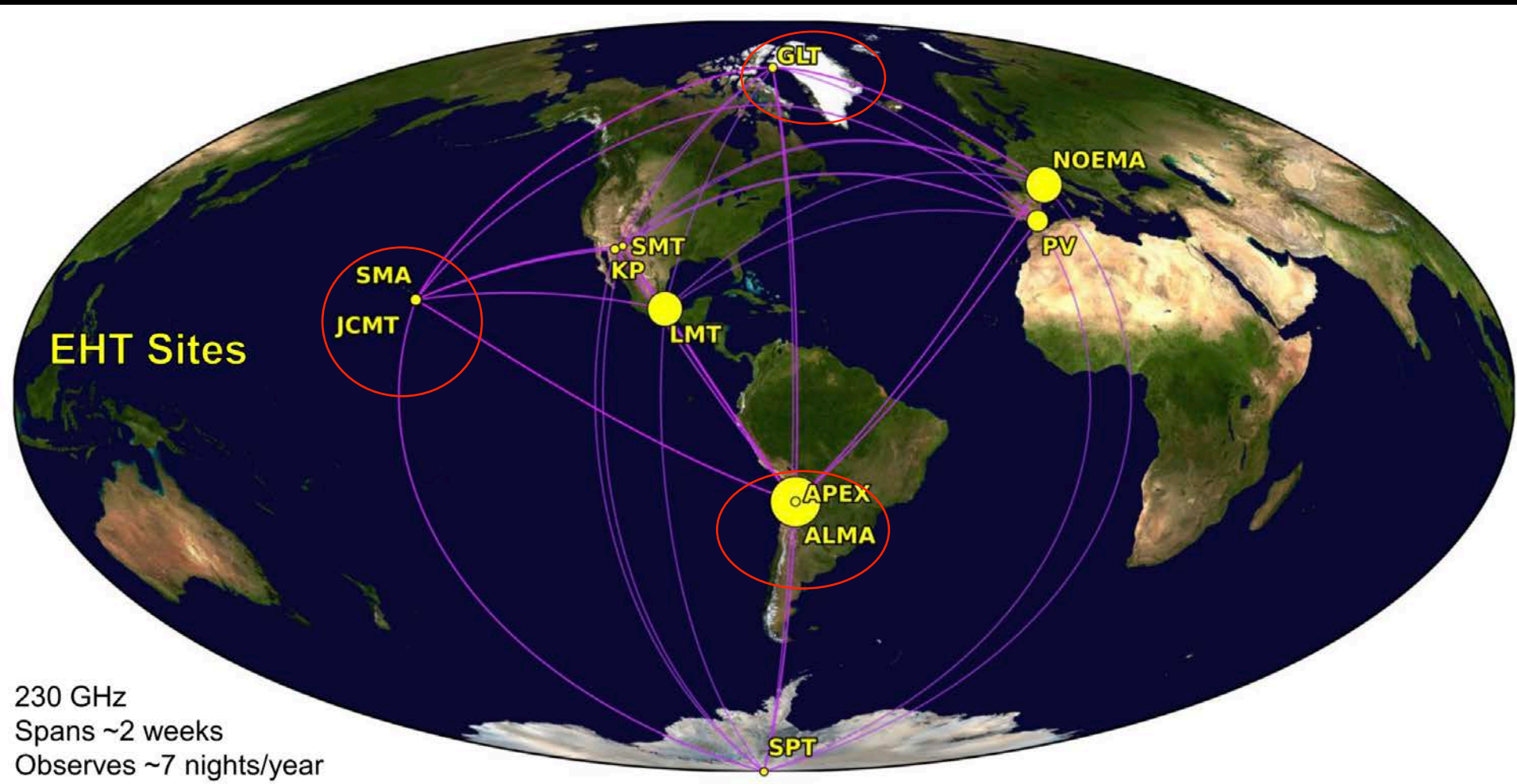

230 GHz  
Spans ~2 weeks  
Observes ~7 nights/year

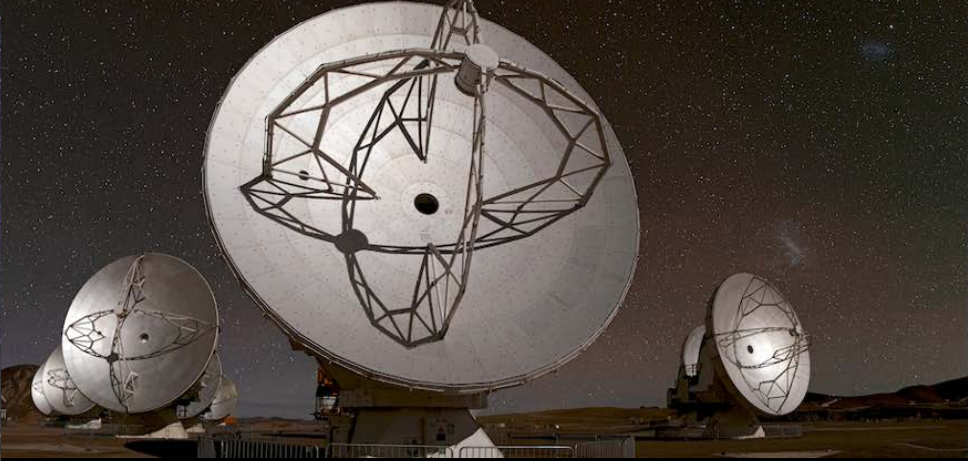
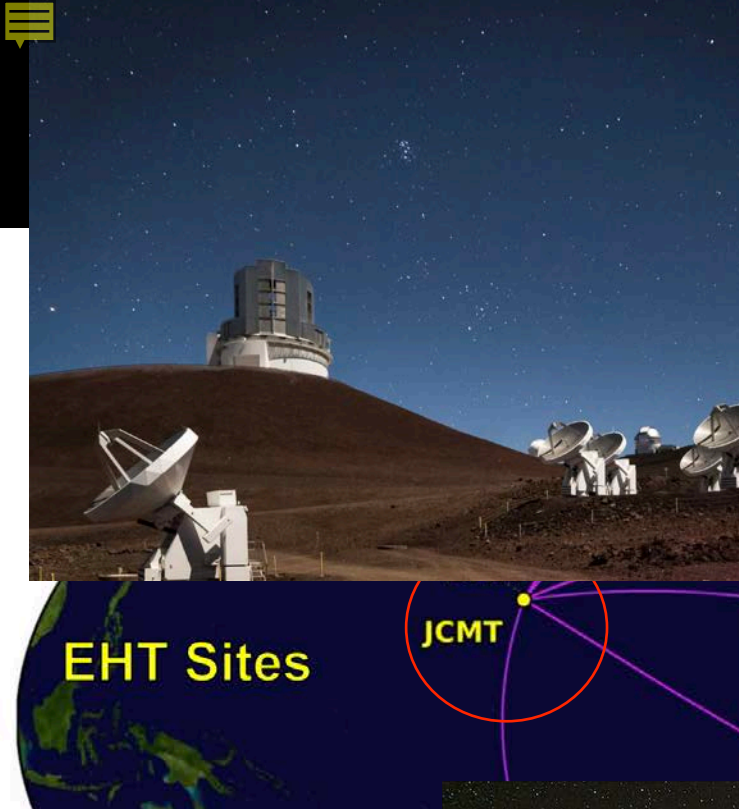

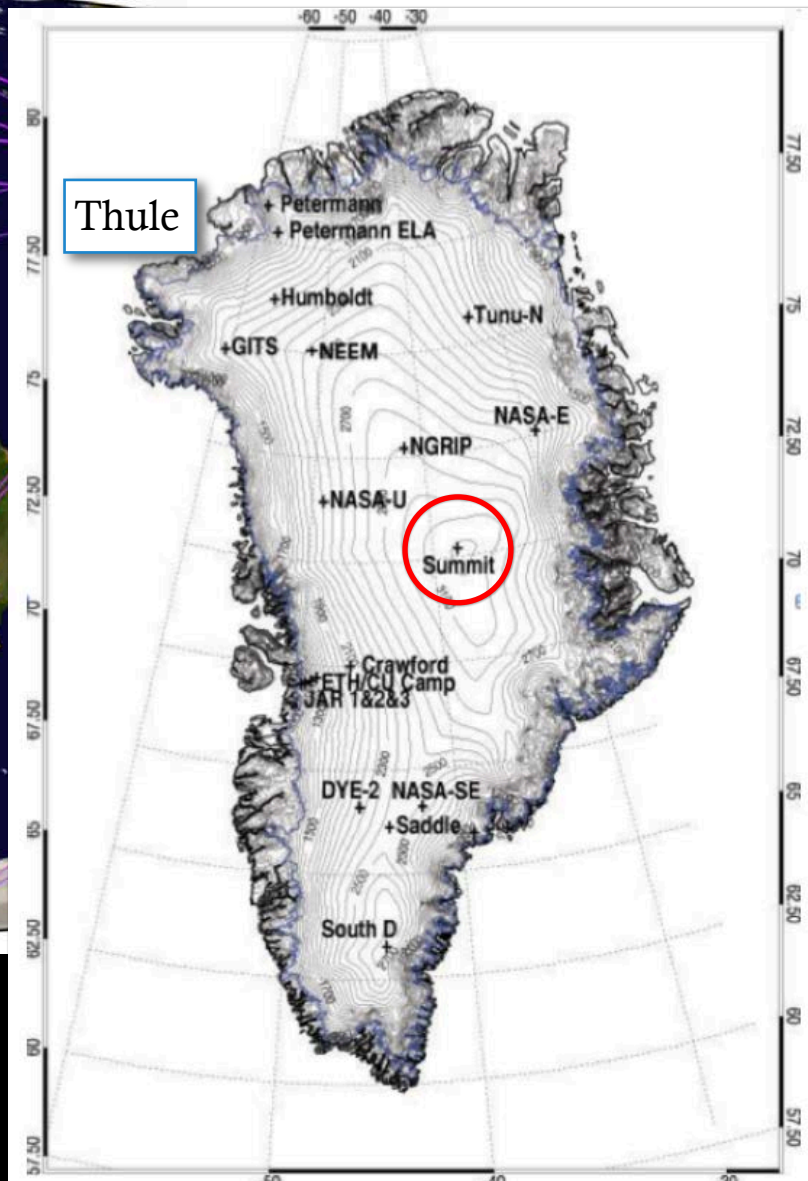
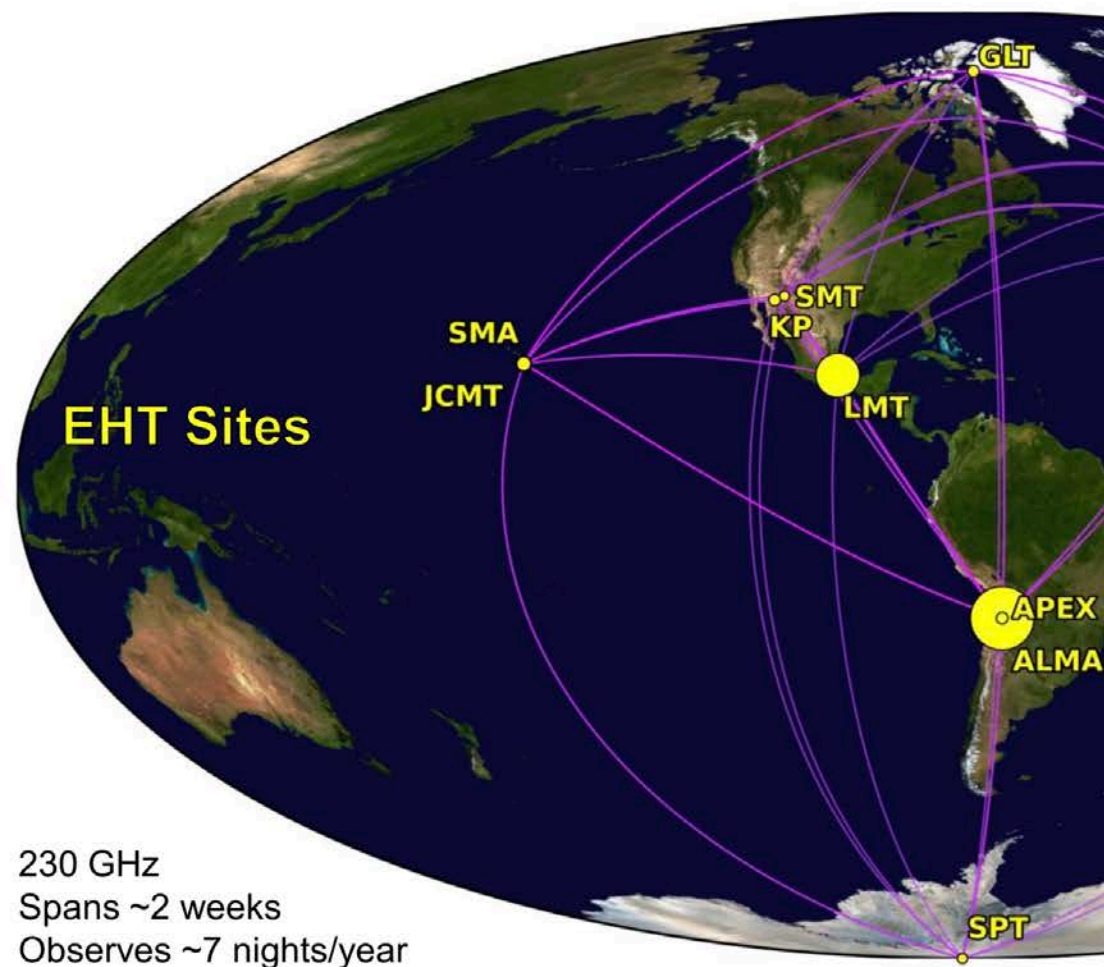

# Current Status

- The Greenland Telescope has been operating in Pituffik (Thule), Greenland!
- First light at the end of 2017!
- VLBI observations (86, 230, 345 GHz) since April 2018 !
- Joined Event Horizon Telescope and Global Mm-wave VLBI Array
- Developed remote/local operations
- 345 GHz fringes detected between GLT and ALMA
- In preparation for moving to Greenland summit.

# A ring-like accretion structure in M87

- Nature, 27 April 2023.
- First publication using GLT data.
- Observed in 2018, right after GLT commissioned.
- GMVA Collaboration
- Frequency: 86 GHz
- More results to come from EHT observations.

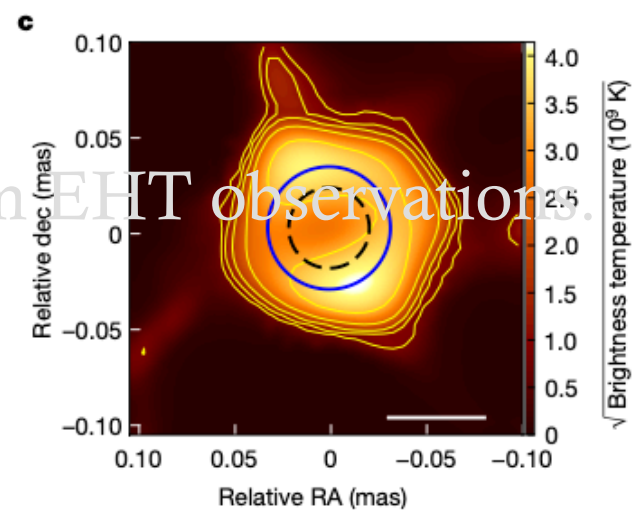
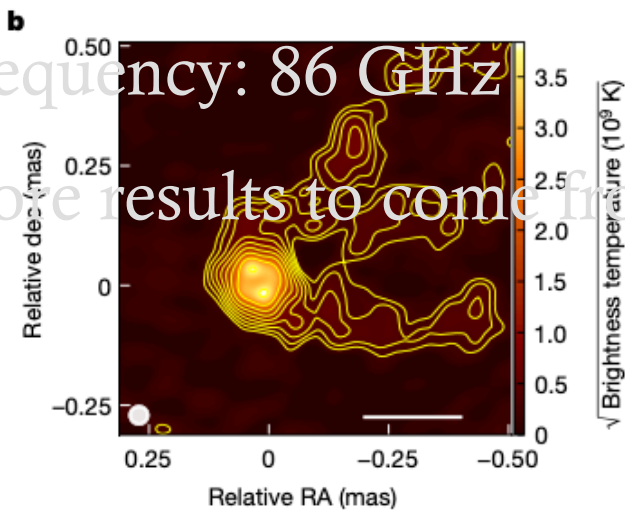
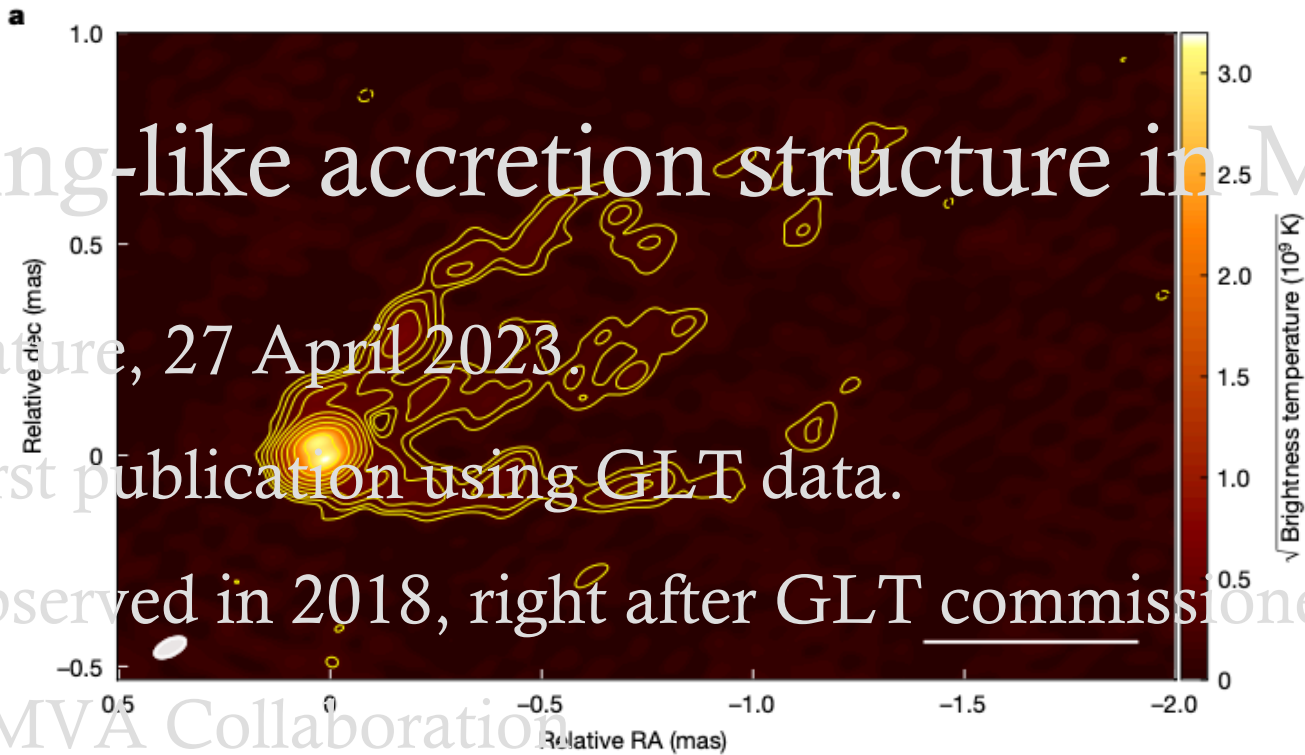

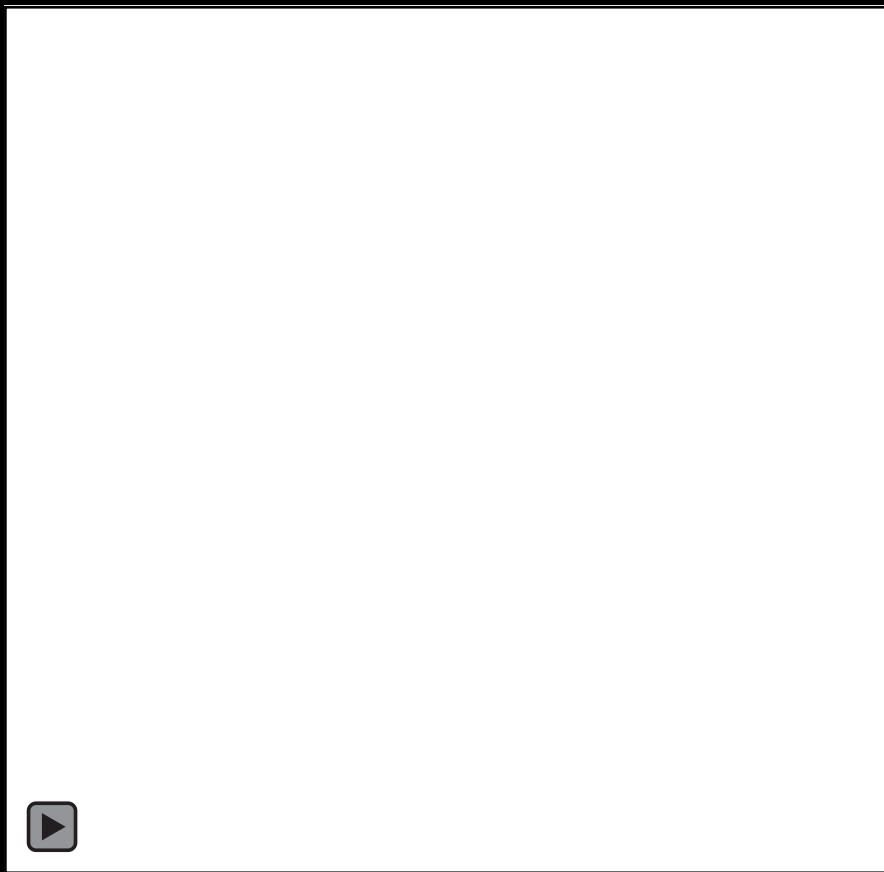

# The Image of a Black Hole

## Black holes

**Black holes** are so compact that light passing nearby is bent. Light that crosses the **event horizon** of a black hole is trapped forever. Light passing at a precise distance will orbit the black hole many times before escaping or falling in.

**Supermassive black holes** live at the centers of galaxies. The Event Horizon Telescope (EHT) recently captured a picture of the supermassive black hole in M87. This black hole has 2,000,000,000,000,000 times more mass than the Earth!

## The Shadow and Photon Ring of a Black Hole

Supermassive black holes are bathed in glowing gas that is heated to billions of degrees. Because their extreme gravity traps light, black holes cast a **shadow** on this bright emission. The shadow is surrounded by a bright **photon ring**.

The photon ring is composed of a series of **increasingly sharp subrings**. Each subring  $n$  is produced by photons that traveled around the black hole  $n/2$  times before reaching the observer. These subrings stack to give the full image.

## Ultra-Sharp Black Hole Images

Photon subrings contain rich information about the black hole but are difficult to see. Nevertheless, they could be studied with an **interferometer**, which joins multiple telescopes. For M87, the  $n = 1$  subring could be seen by extending the EHT to low Earth orbit, and  $n = 2$  could be seen with a telescope on the Moon.

Reference: *Universal Interferometric Signatures of a Black Hole's Photon Ring*  
Credit: Michael D. Johnson (CfA), Simulation: George Wong (UIUC)

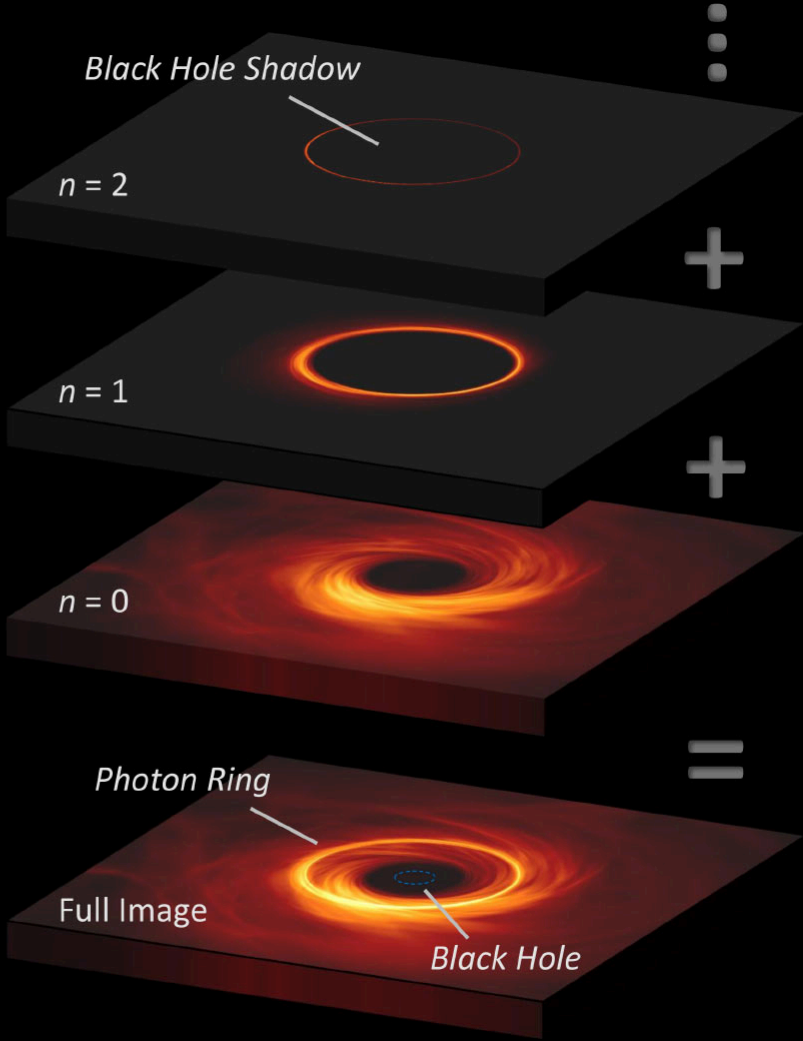

Shadow Diameter  $\sim 5.2$  \* Schwarzschild Radius

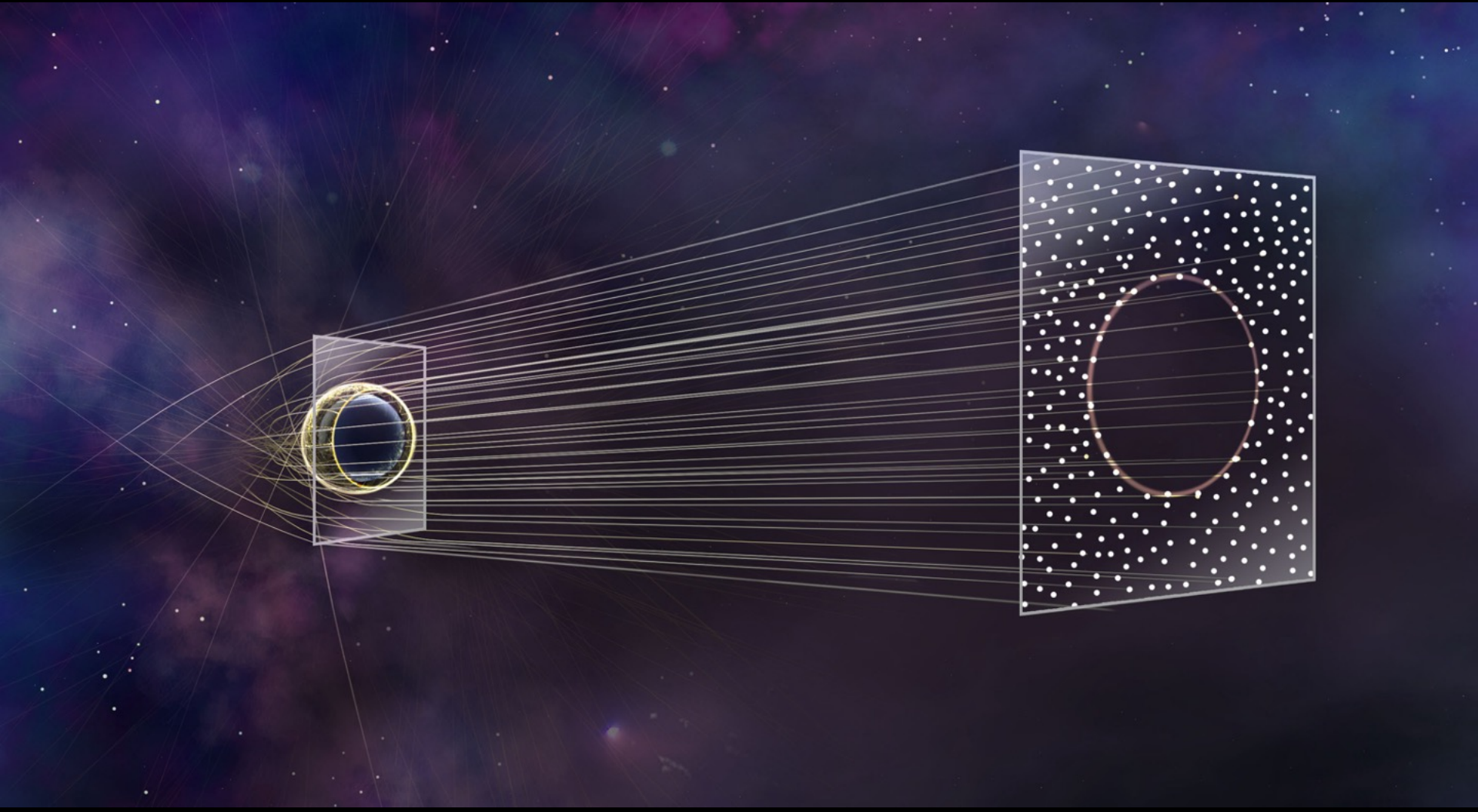



Time-averaged image of a general relativistic magnetohydrodynamic simulation of the supermassive black hole in Messier 87. Image credit: Johnson *et al*, doi: 10.1126/sciadv.aaz1310.

# EHT Coverage

Orthographic Map Centered on Lon=180, Lat=12.391123

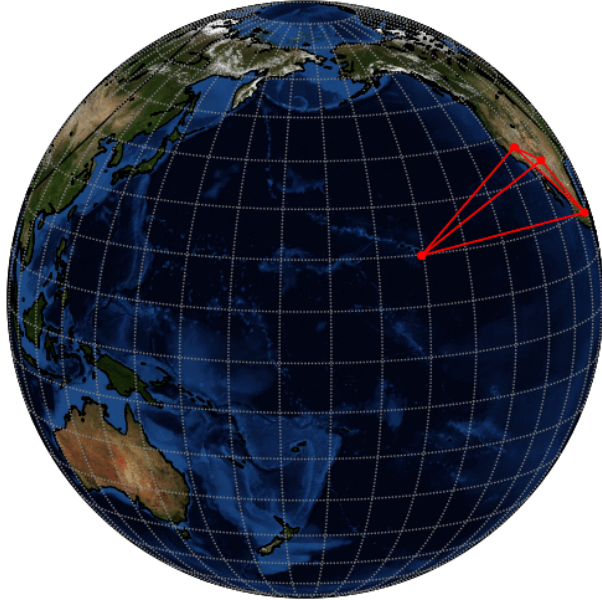

UV plane

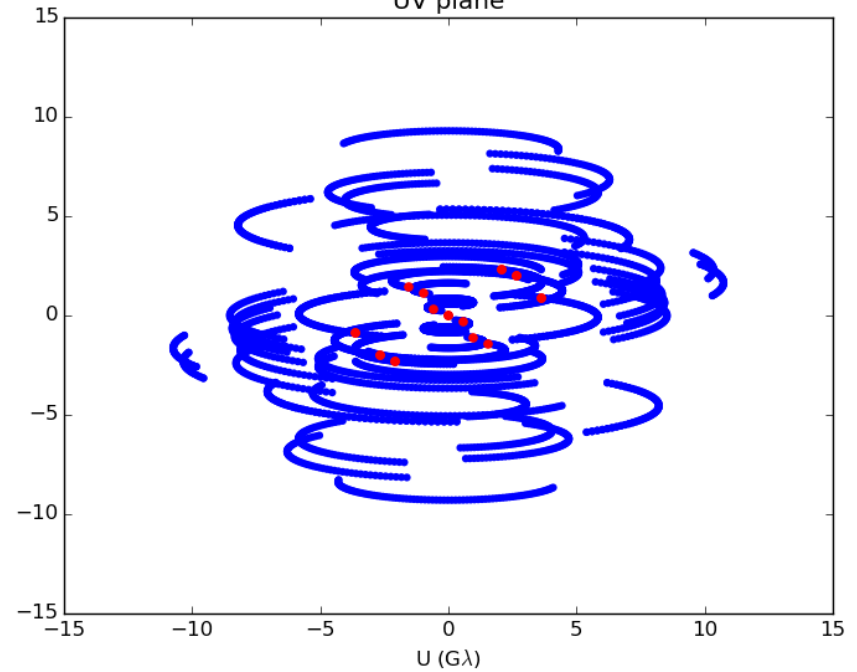

Animation: Laura Vertatschitsch (SAO)

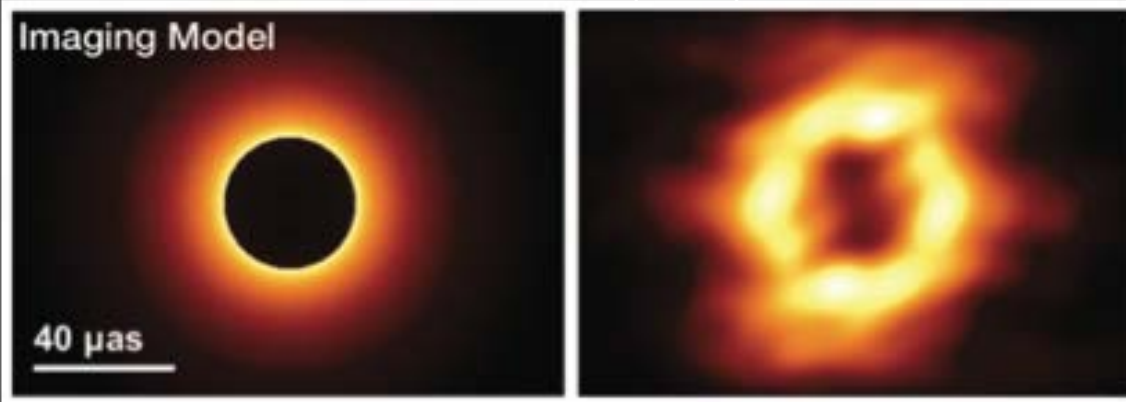

Simulated image of the shadow of the black hole of M87.

Left: Model image, Right: simulated submm VLBI observed image including GLT at 345 GHz. (Pu et al.2016).

# How to image photon ring?

- Increase angular resolution:
  - Extend VLBI baselines; launch satellites
  - Observe at higher frequencies;  $> 230$  GHz, few available sites
- Reduce optical depth:
  - Observe at higher frequencies
- Add more VLBI stations

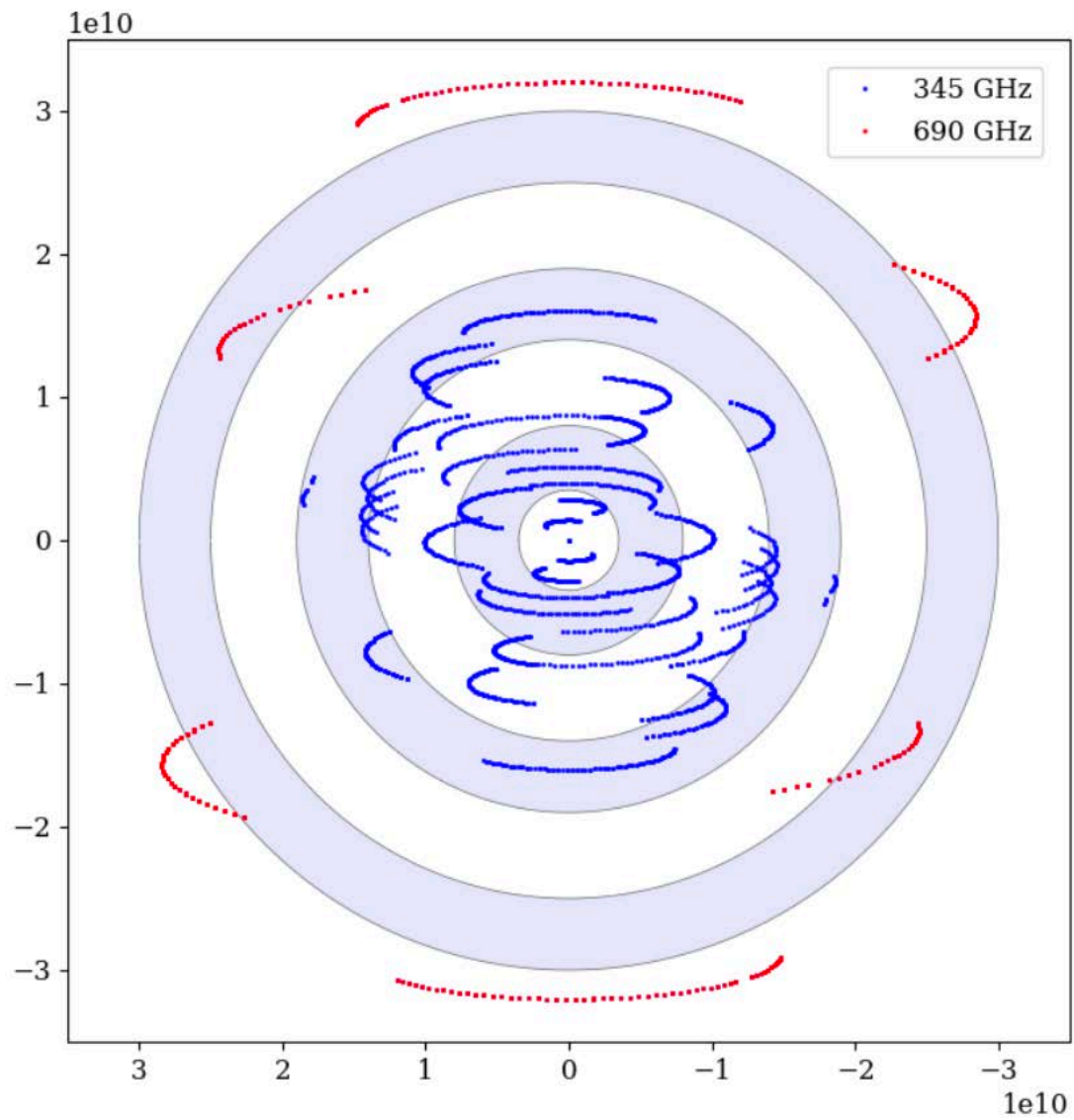



# Greenland Summit

- Criteria for new submm site for VLBI
  - High and dry submm sites
  - Mutual visibility with SMA and ALMA
  - Logistics and accessibility
  - Unique VLBI baseline

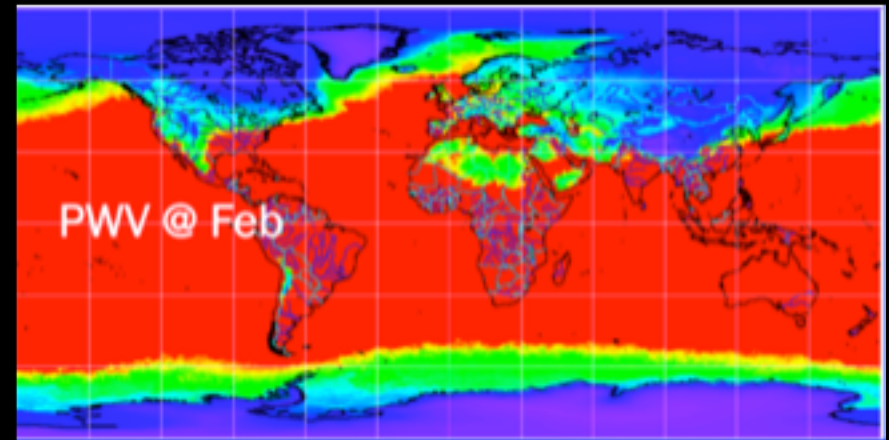
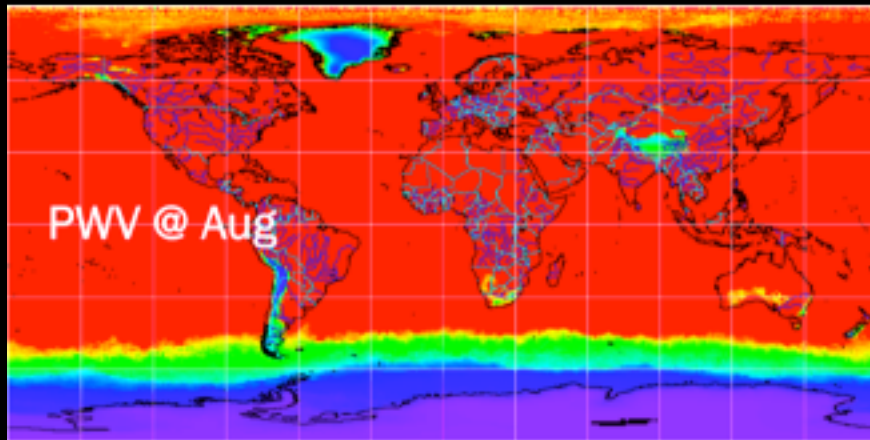

# Greenland Summit

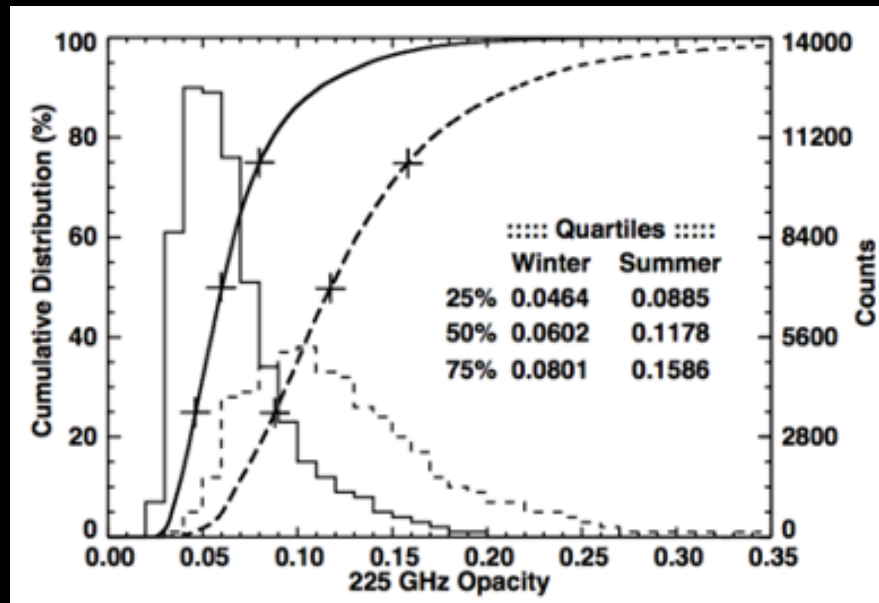

TABLE 1  
COMPARISON OF 225 GHz OPACITY QUANTILES  
BETWEEN THREE SITES.

Site	Season	Quartiles		
		25%	50%	75%
Greenland	Winter	0.046	0.060	0.080
	Summer	0.089	0.118	0.159
ALMA	Winter	0.035	0.050	0.080
	Summer	0.071	0.131	0.261
South Pole	Winter	0.041	0.048	0.057
	Summer	0.050	0.062	0.076

Matsushita, S. et al 2017,

# Greenland – Summit Station

- Established/operated by US NSF & Greenland Government.
  - Atmospheric and weather researches are main topics. Established in 1989.
  - N72.60°, W38.42°. Altitude: 3210m.
  - Summer: 45 people, Winter: 5 people (3 months shift)
  - Possible to carry things by flights with C-130, etc., or through land
  - Currently under expansion (Recapitalization)

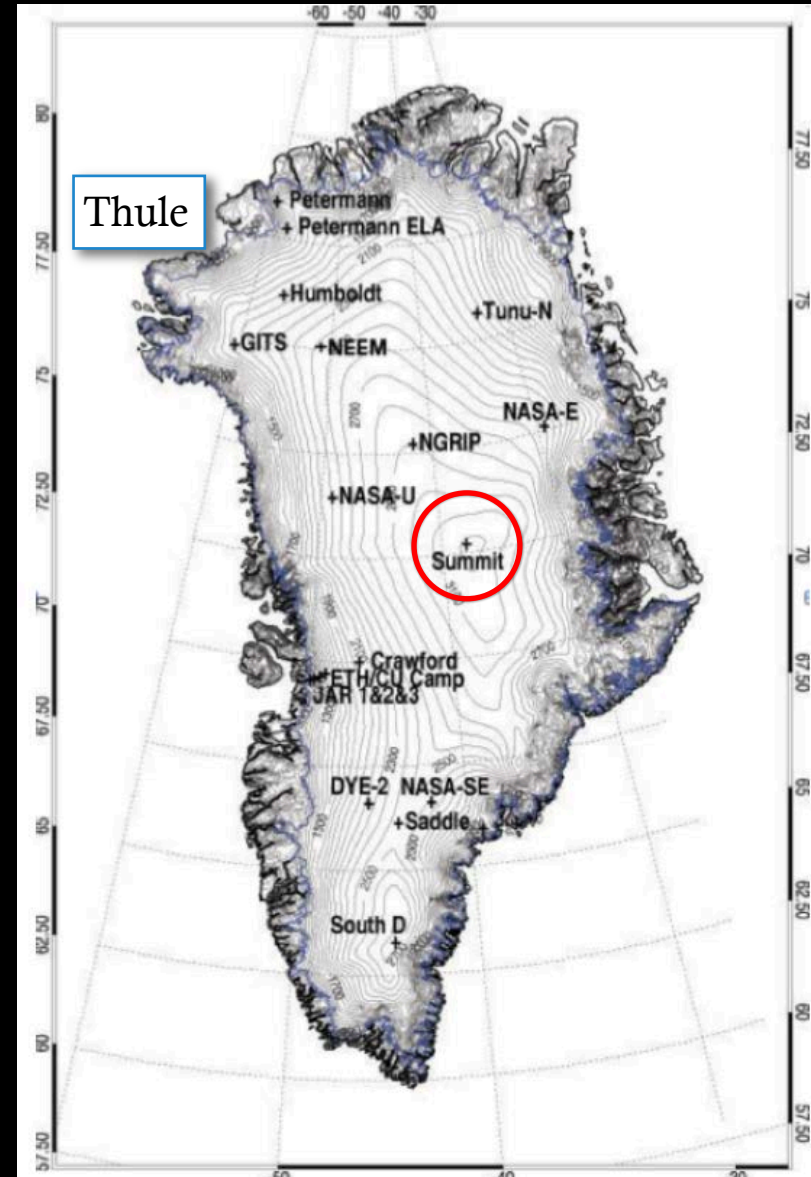

# Greenland – Summit Station

- Established/operated by US NSF & Greenland Government.
  - Atmospheric and weather researches are main topics. Established in 1989.
  - N72.60°, W38.42°. Altitude: 3210m.
  - Summer: 45 people, Winter: 5 people (3 months shift)
  - Possible to carry things by flights with C-130, etc., or through land
  - Currently under expansion (Recapitalization)

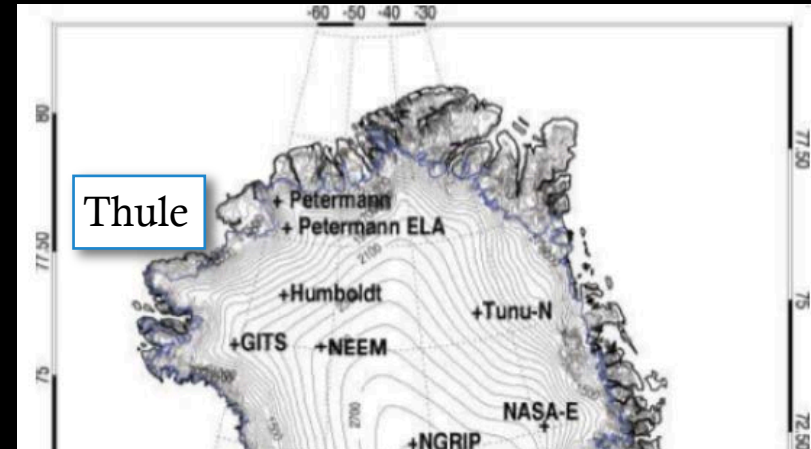

2020: In operation, Thule, Greenland



# GLT Specifications

## Antenna characteristics

Keyword	Value
Primary Aperture	<u>12.0 m</u>
Focal Length (Primary)	4.80 m
fp / D of Primary	0.40
Secondary Aperture	0.75 m
Final f / D	<u>8.00</u>
Primary Illumination (Edge Taper)	<u>12 dB</u>
Magnification Factor	20.0
Primary Angle of Illumination	128.02°
Secondary Angle of Illumination	7.16°
Distance from Primary to 2nd Foci	6.177 m
Depth of Primary	1.875 m
Primary Vertex Hole Clear Aperture	0.75 m
Elevation axis travel range	+1.89° to +90°
Azimuth axis travel range	-180° to +360°
Total weight	<u>112 Metric ton</u>

## Required operating conditions on Greenland's Summit

Keyword	Primary	Secondary	Survival
Ambient temperature	0 to -50 °C	-50 to -55 °C	-55 to -73 °C
Vertical temperature gradient*	+12K to -1K	+15K to -2K	N/A
Wind speed	0 to 11 m/sec	11 to 13 m/sec	55 m/sec

# GLT Subsystems

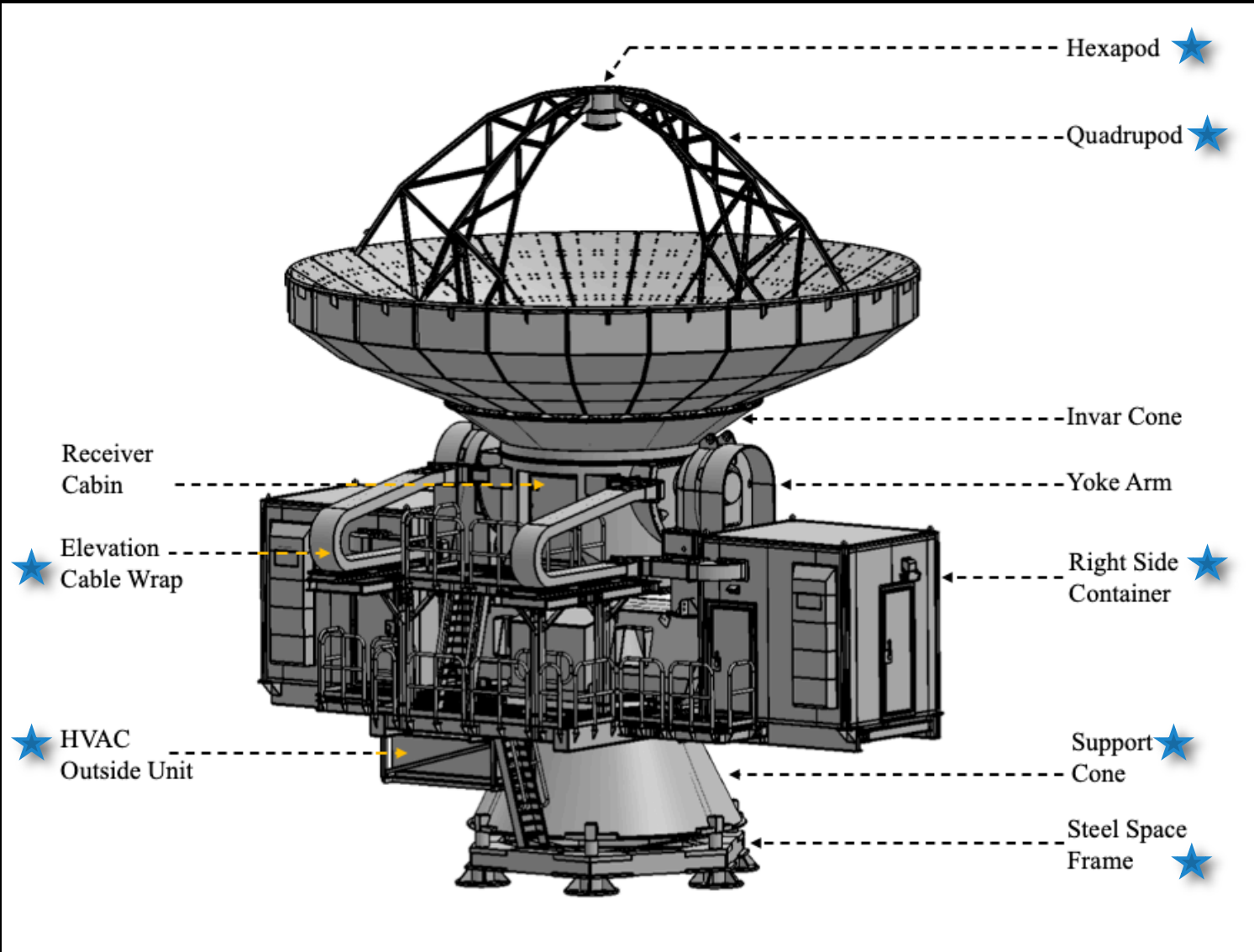

# GLT Orientations

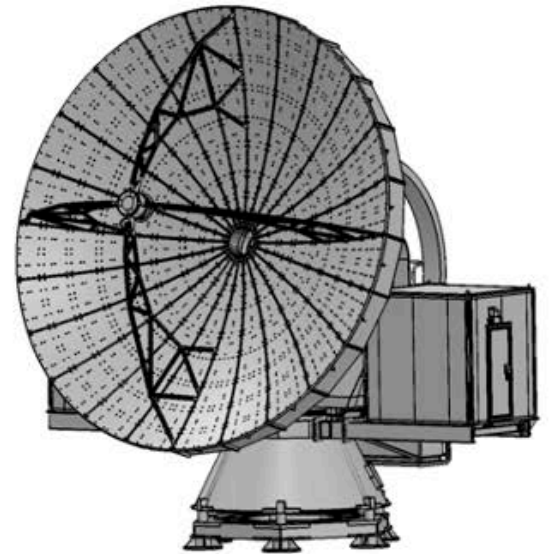
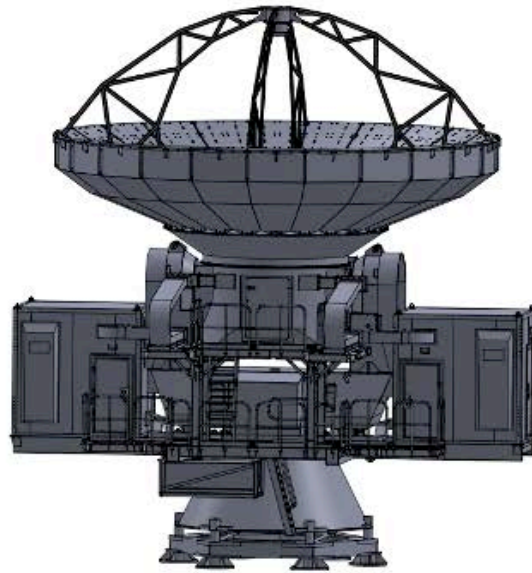
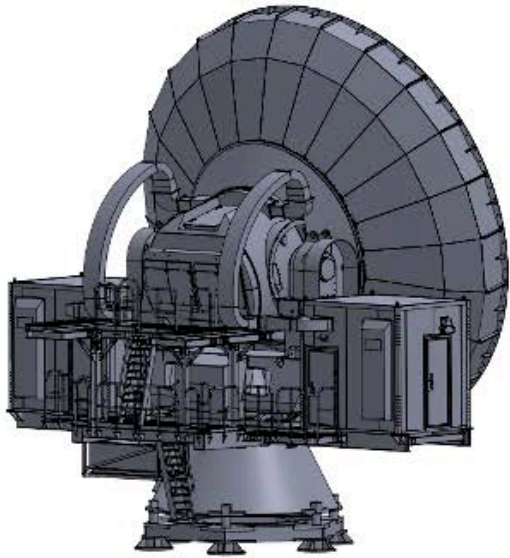

# GLT Nutator (Hexapod)

Table 3

GLT hexapod sub-reflector characteristics

Keyword	Value
Min. dynamic loading	53 kg
Dimensions	Dia. 580 mm, Ht. 613 mm
Total weight	67 kg
Interface material	Invar
Movement in x and y axis	
- Distance	+/- 5 mm from center
- Slewing Mode	Less than 0.5 mm/sec
- Collimation mode	Min. steps of 20 $\mu$ m, 10 $\mu$ m differential accuracy
Movement in z axis (optical axis)	
- Distance	+/- 10 mm from center
- Slewing Mode	Less than 0.5 mm/sec
- Focus adjustment	Min. steps of 20 $\mu$ m, 5 $\mu$ m differential accuracy
- Focus switching	Perform cycles up to +1.5 mm and -1.5 mm with repeatability of +/- 20 $\mu$ m
Nutating <b>-150 C</b>	
- Chopping Range	10 arcmin maximum
- Accuracy	1.3 arcsec
- Direction	Any directions
- Chopping Freq	2 Hz
- Chopping mode	Two-position chopping
- Settling time	Less than 50 ms



# GLT VLBI Receiver

Single cryostat, three receiver cartridges

Keyword	Rx86	Rx230	Rx345
Origin	ASIAA	OPU	IRAM
Polarization	Dual Circular	Dual Circular	Dual Linear
RF freq. range	84 – 96	213 – 231	275 – 373
LO freq. range	80 – 88	221 – 223	283 – 365
1st stage detector	MMIC	SIS	SIS
Mixing scheme	USB after 1st mixer	2SB	2SB
# of IF channel	2	4	4
IF (GHz)	4 – 8	4 – 8	4 – 8
VLBI LO freq. (GHz)	80.6	221.1	342.6
TSSB (K) 80% LO range (All)	90	70 (110)	147 (219)

# First Light

**Cryosta**

t

**WCA**



# GLT Cryostat (2<sup>nd</sup> Version)

## 冷凍腔體剖面示意圖

此特殊設計的壓縮機可提供  
三個不同溫度層的橋界面

冷凍壓縮機

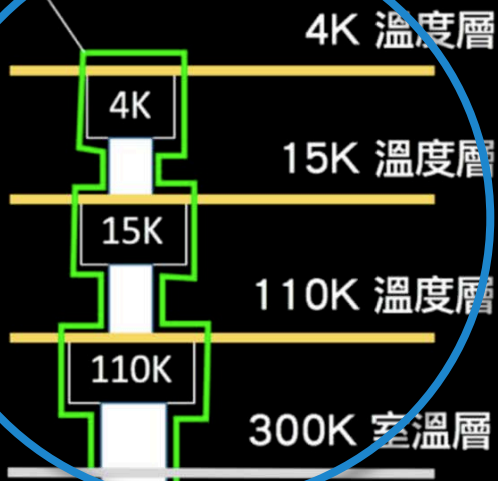

壓縮機馬達

230GHz  
接收機

冷凍壓縮機

86GHz  
接收機

345GHz  
接收機

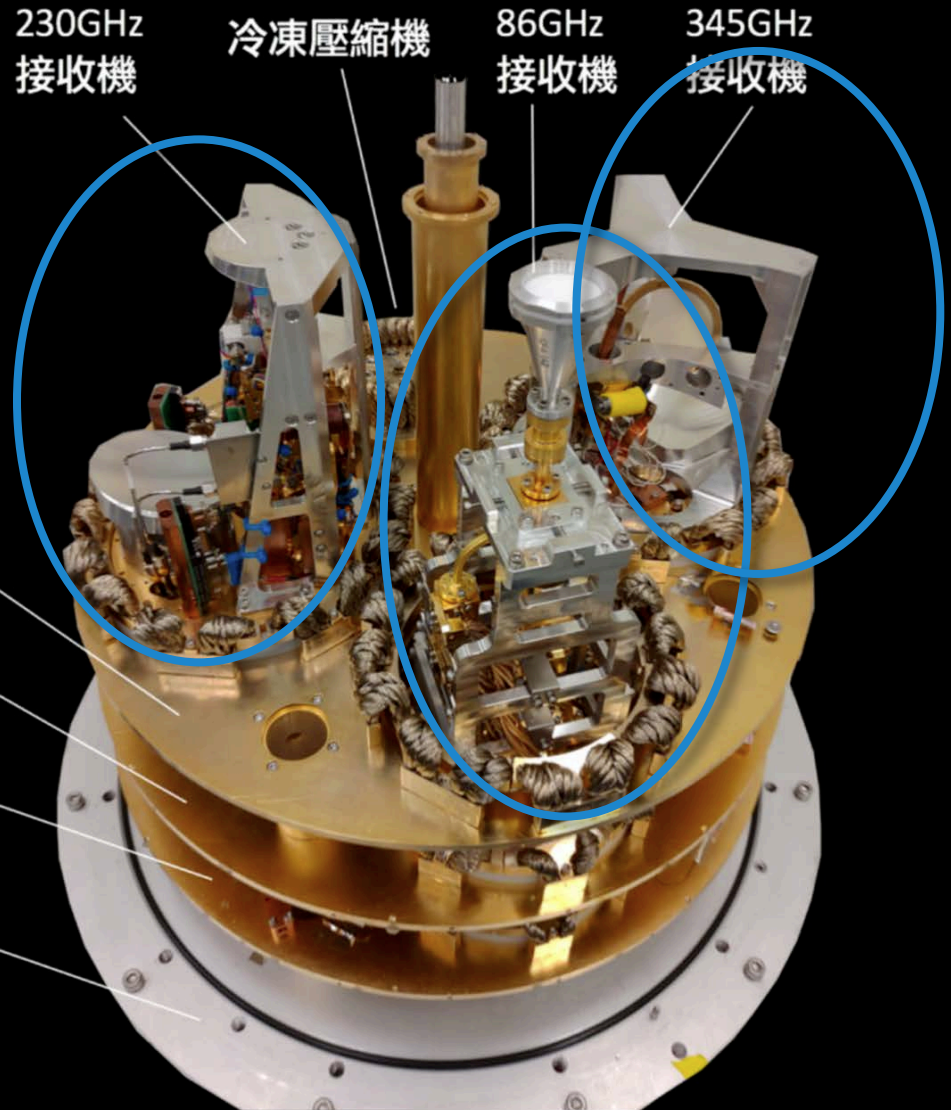

# JCMT Installation



# Reference Signals Distribution

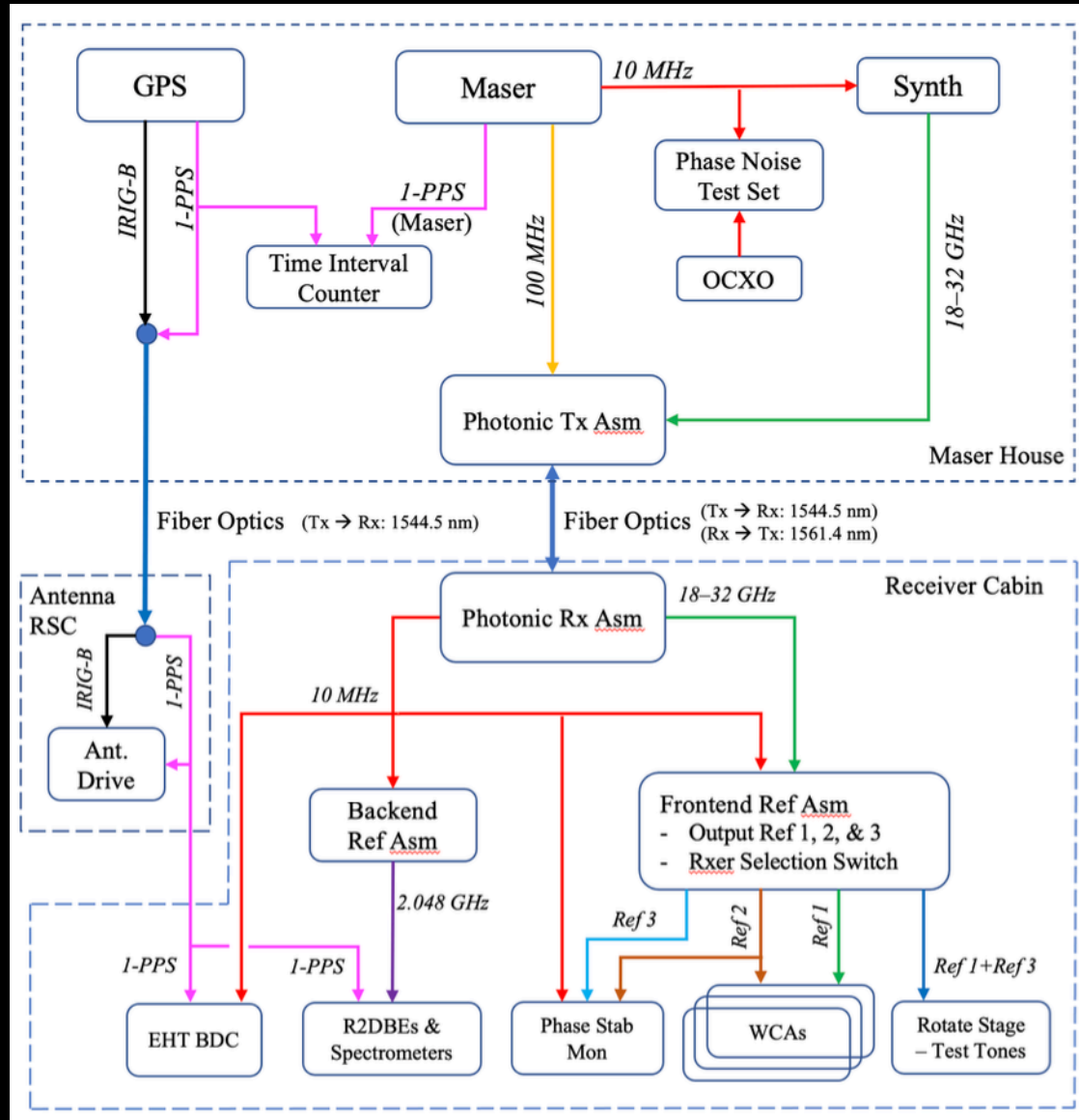

# Receiver LO/IF Distribution

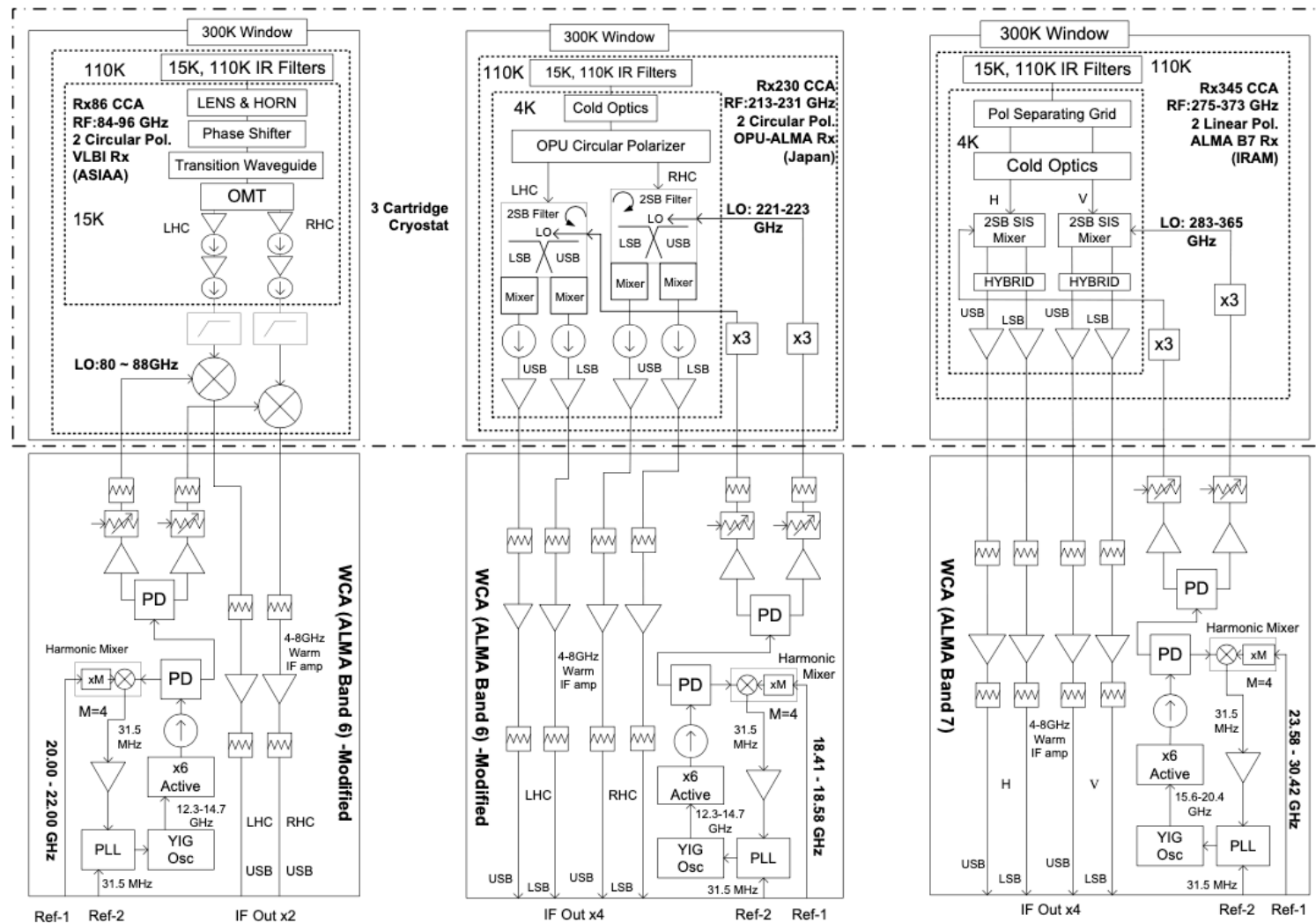

# IF/Baseband Processing

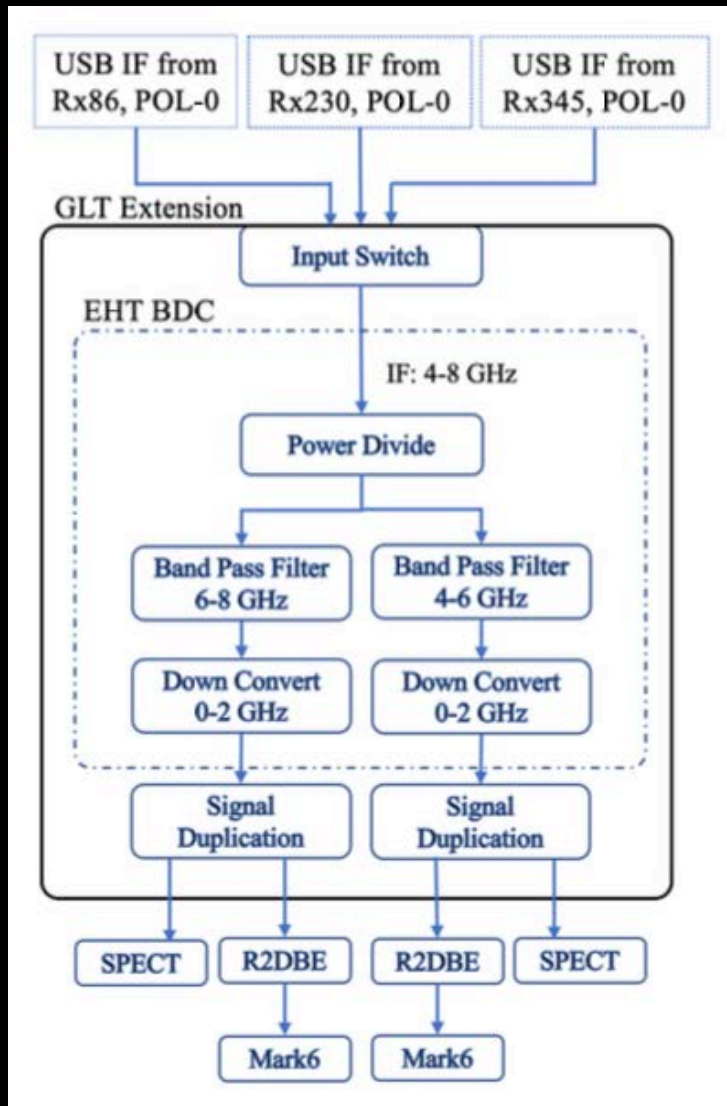

- Extended Block Down Converter x 2
- Input switch select receiver channel
- IF: 4-8 GHz  $\rightarrow$  2 blocks of 0-2 GHz
- Duplication of signals; one sent to R2DBEs, and one to spectrometers
- R2DBE digitizes the blocks and sent to Mark6 recoder

# Test Tones Gen/Processing

- Critical setup for VLBI observations
- Tone sources for all three receiver cartridges
- When needed, a rotation arm will move the source into the signal beam
- Designed to generate a tone  $\sim 6.0$  GHz
- Compare the signal with reference and ensure stable phase

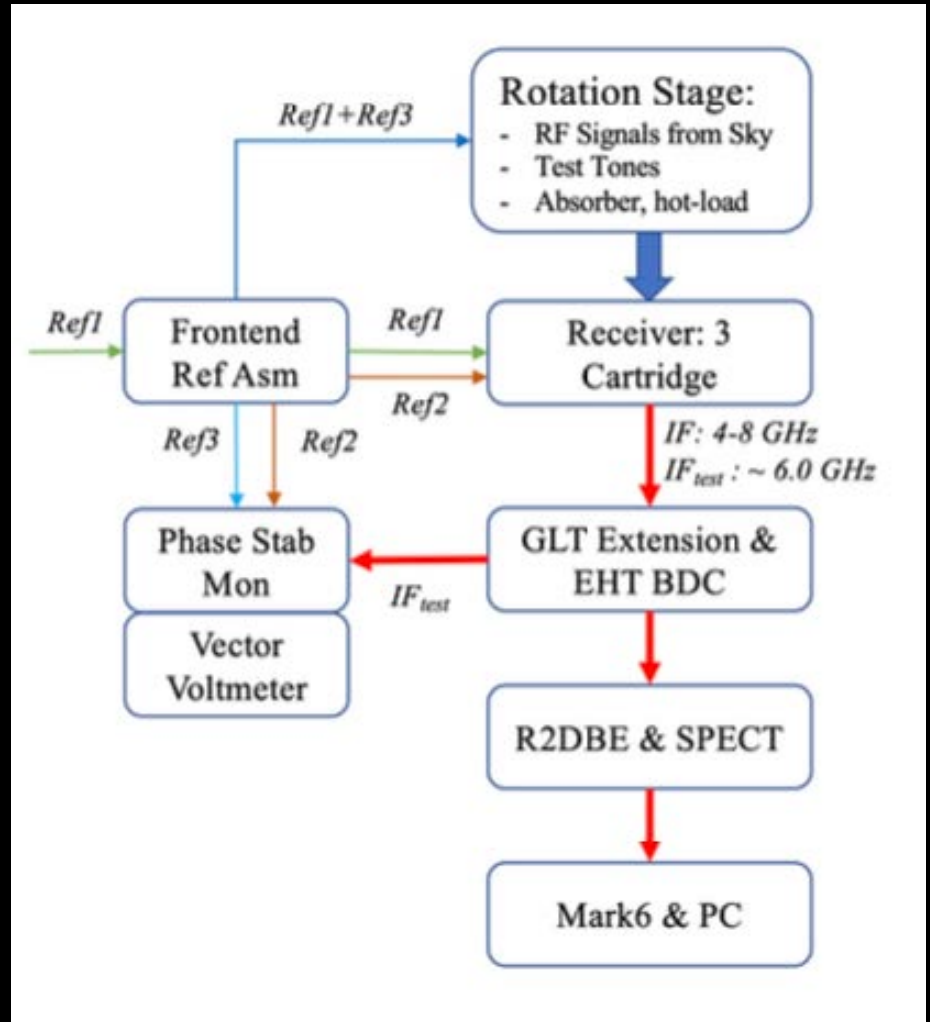

# Photogrammetry

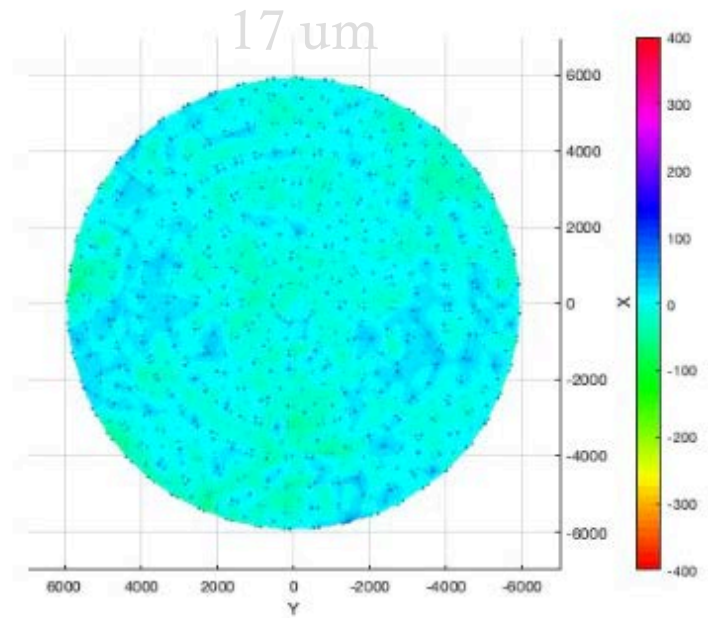
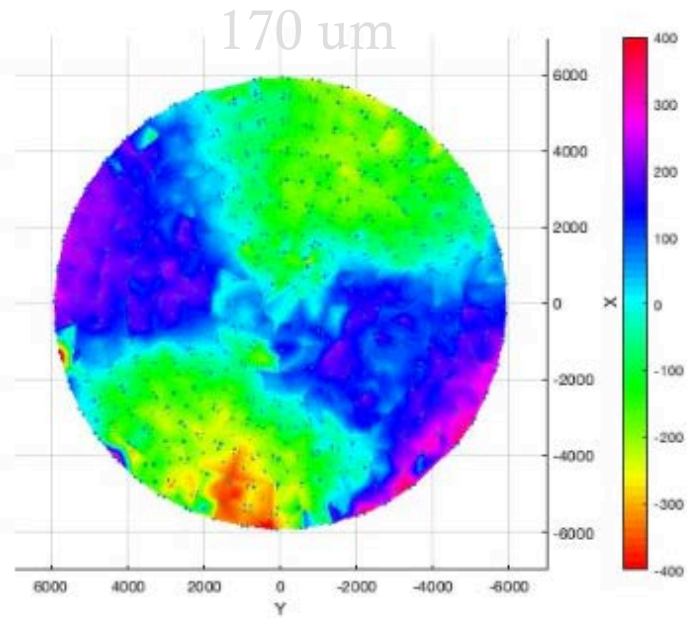

# Antenna Control System

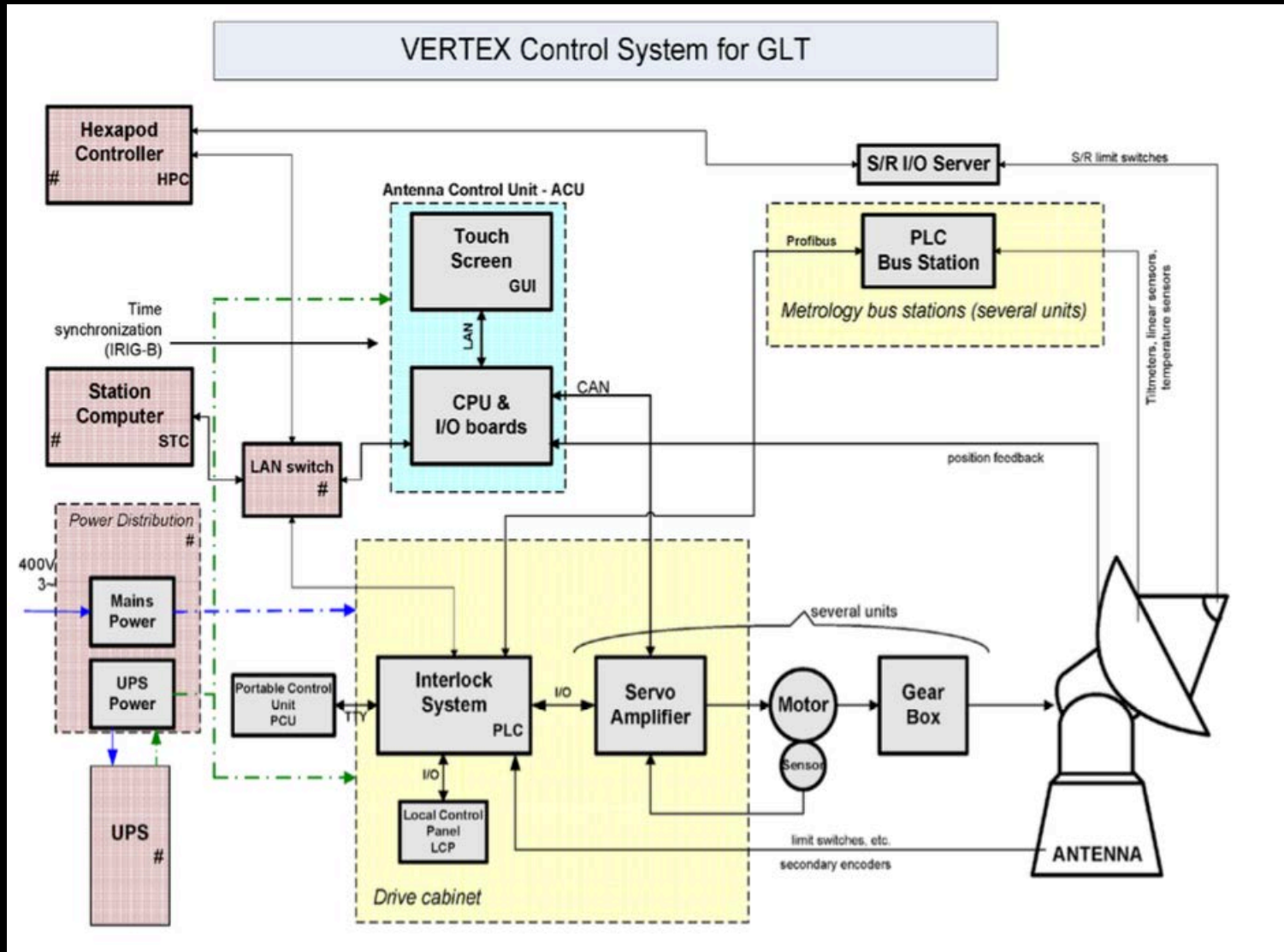

# Fringe Detection with ALMA 2018

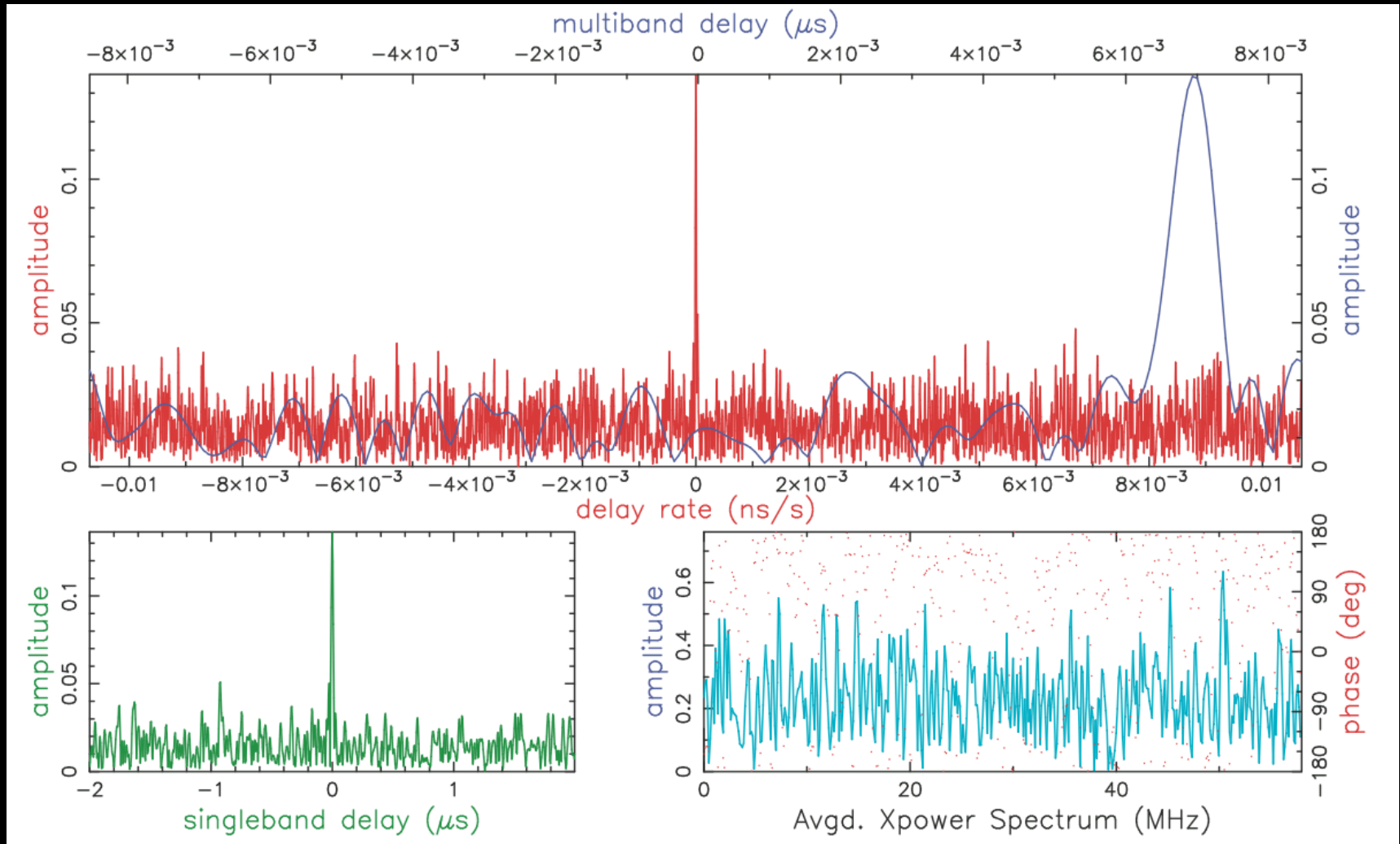

# Moving to Summit

- A difficult, dangerous, and expensive journey
- High operation cost on Summit
- Difficult to access; summer or winter
- But doable nevertheless
- Highest resolution achievable from ground
- VLBI at 690 GHz: Black hole photon rings

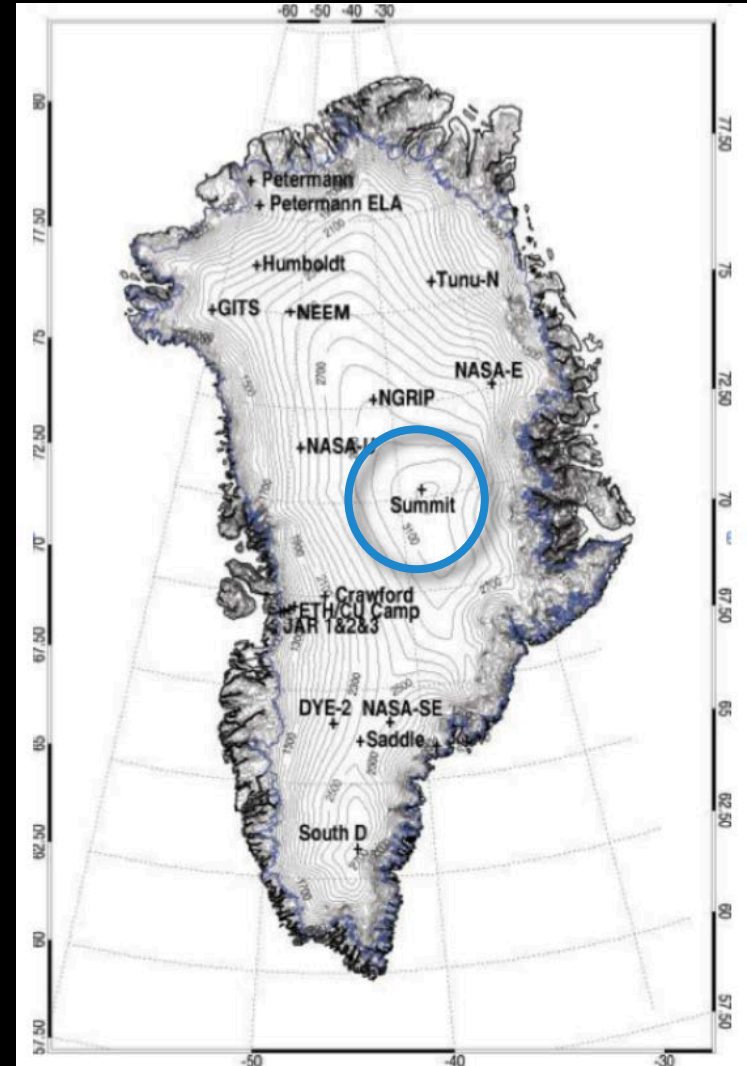

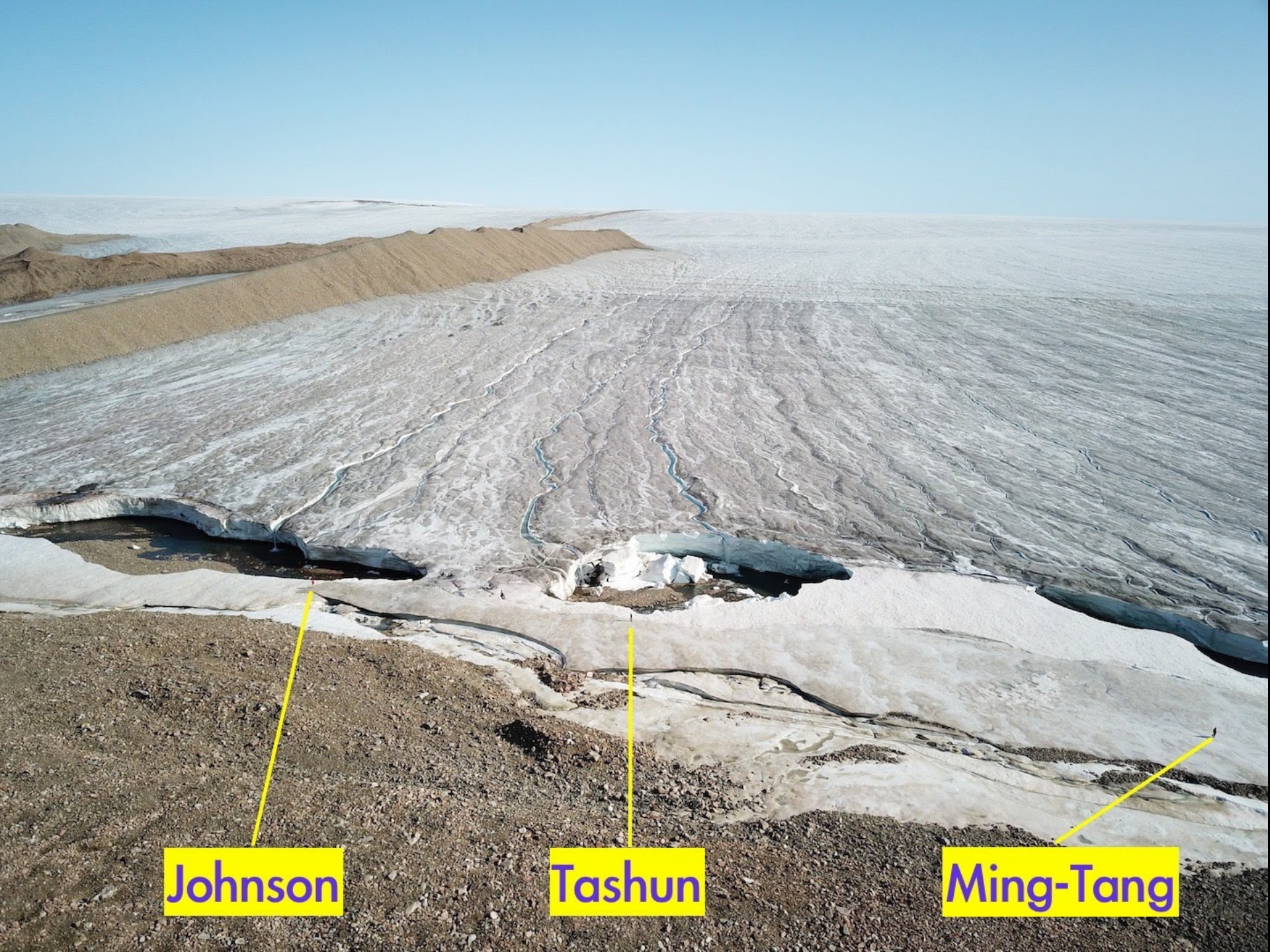

**Johnson**

**Tashun**

**Ming-Tang**



Courtesy of JP Steffensen @ EGRIP

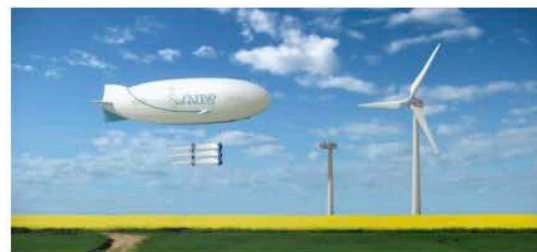

# T on Skis

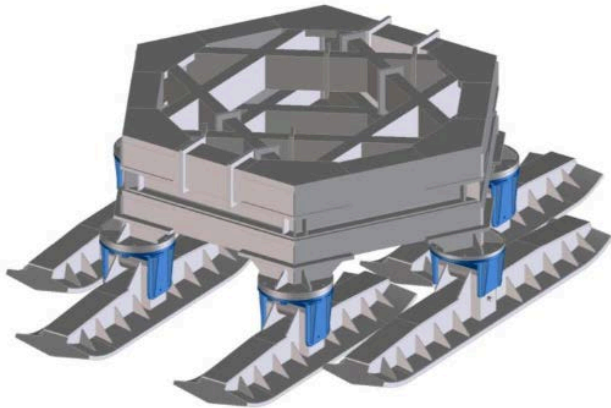
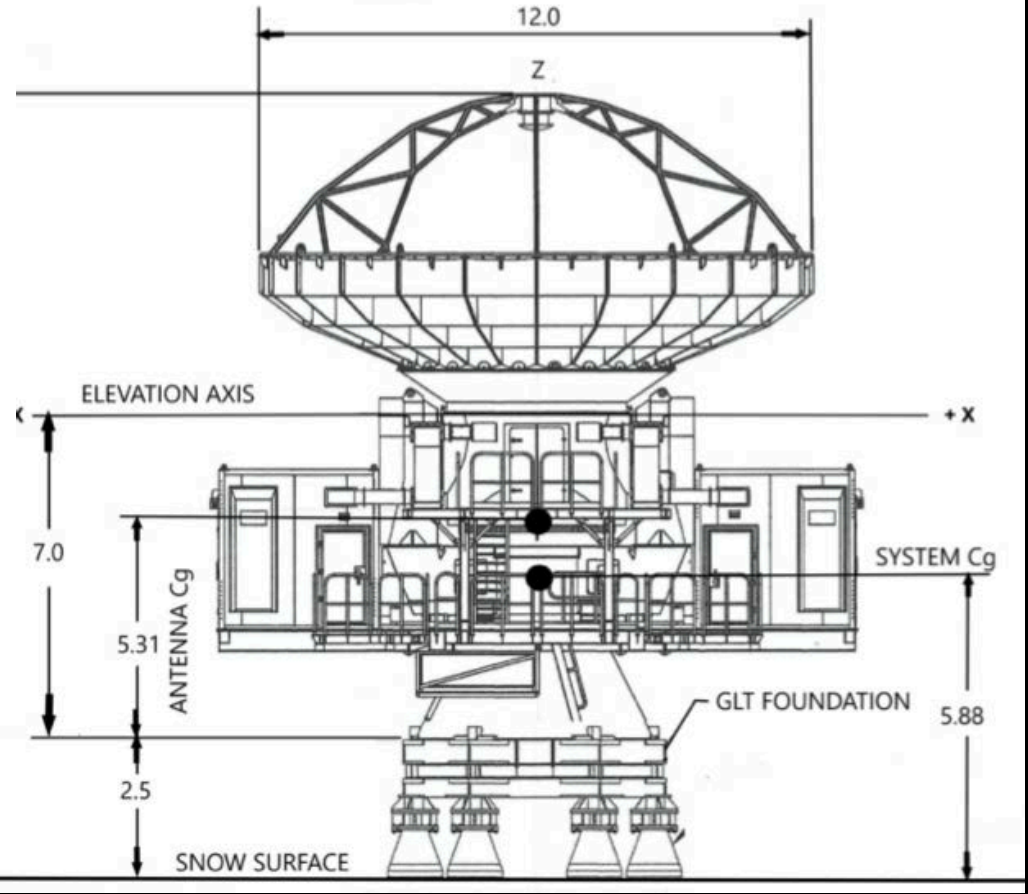
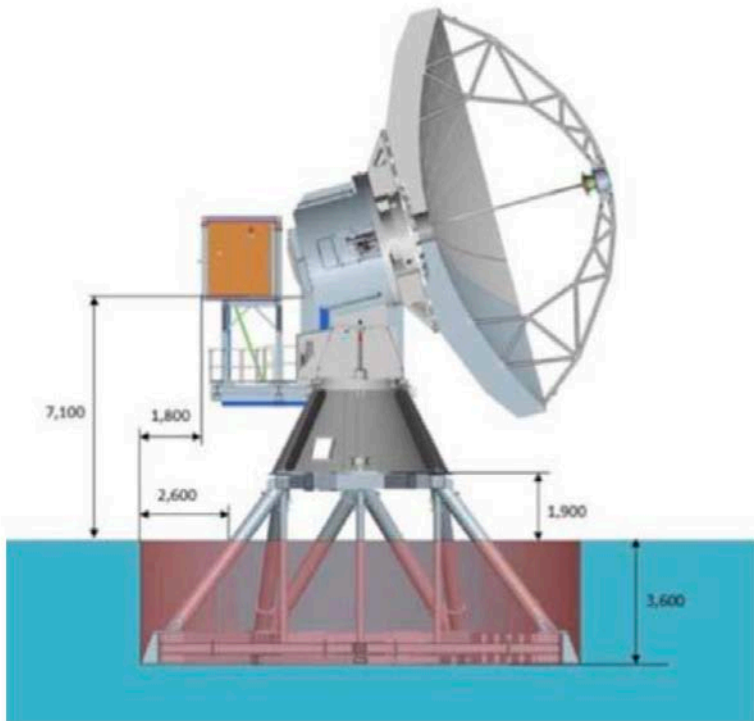

# Current and Future Resolution of EHT

## EHT with GLT

220 GHz  
5 x 5 pix (25 pix)

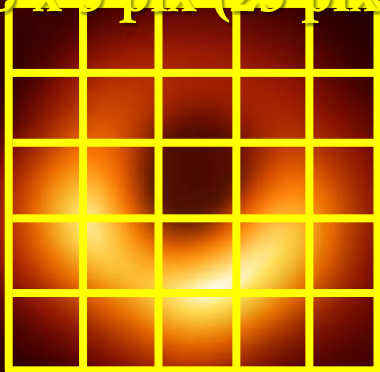

We will have better resolution & sensitivity on M87 black hole shadow &

## EHT 2017

220 GHz  
3 x 3 pix (9 pix)

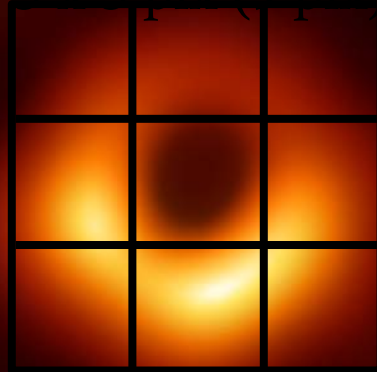

## GLT @ Summit

660 GHz  
15 x 15 pix (225 pix)

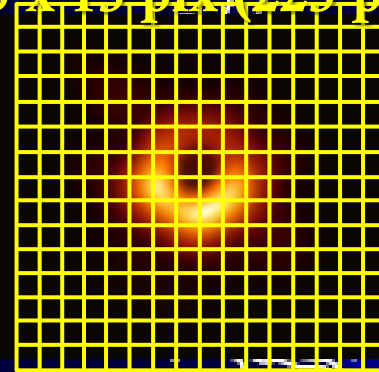

M31 (Andromeda)  
Black Hole

We will have much better resolution for black hole

# Summary

- One and only submm radio telescope in the polar region
- A critical station for submm VLBI observations
- For optimal outcome: Move to Summit Station
- However difficult: Ultimost resolution for photon ring (from ground)

<https://doi.org/10.1088/1538-3873/acf072>

Ming-Tang Chen *et al* 2023 *PASP* **135** 095001